

High Temperature Non - Slam Check Valve Type HTCVC - FE DN200(8")-1200(47") ANSI 150/PN16

Description:

HTCV – non – slam check valves are used in pressurized piping systems. Valves are of double eccentric, fabricated design. This permits quick raising and late resetting of the disc-seal from/on the sealing surface. Therefore the wear of sealing elements is very low.

HTCV – non – slam check valves have double sealing system on the shafts and special metallic lamellas seal for long term tightness. Due to sealing materials HTCVC non – slam check valves may be used in liquid and gaseous service for temperatures up to 150°C (max. temp. 350°C after adaptation of bushings and seal systems).

Main materials:

Parts	Type standard
Body	ASTM283 S235JR
Seat ring	AISI304 X5CrNi18-9
Shaft	AISI403 X20Cr13V
Shafts Seals	EPDM / Viton
Bushings	INA / Deva
Main sealing ring	Lamellas / matalic / gaskets
Disc	ASTM537 S355J2G3
Clamping ring	ASTM283 S235JR

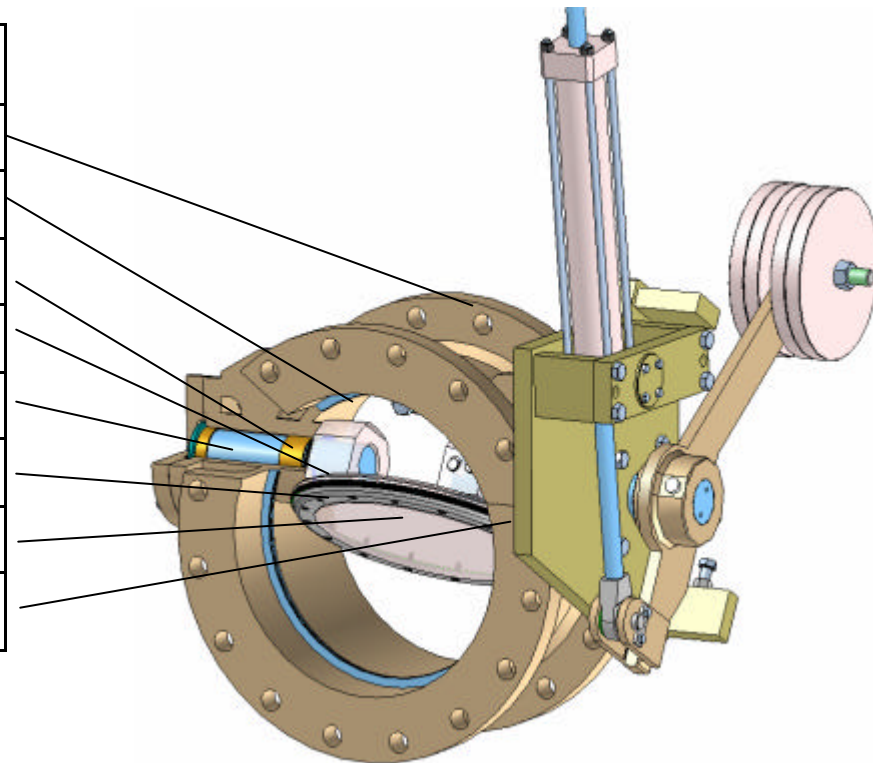

Other materials are available upon request
Painting for standard valves: coating - Friezink S

General design

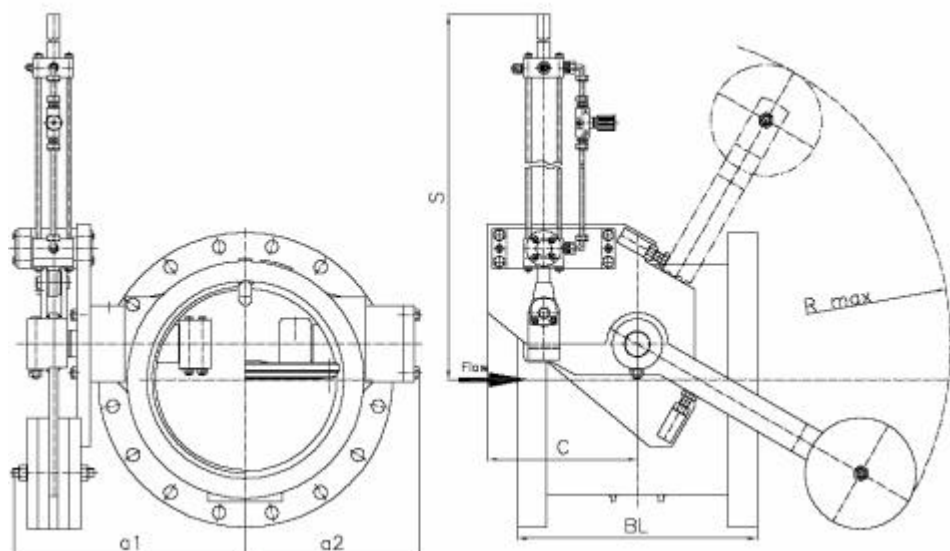

**High Temperature Non - Slam Check Valve
Type HTCVC - FE
DN200(8")-1200(47") ANSI 150/PN16**

Dimensions and weights for standard range of HTCVC-FE valves

(other sizes and pressure ratings are available upon request).

DN	BL	ANSI 150/PN16					
		a1	a2	C	S	R max	Weight drive 3
[mm]	[mm]	[mm]	[mm]	[mm]	[mm]	[mm]	[kG]
200	250	450	320	450	1000	600	350
250	250	450	320	450	1000	630	380
300	270	480	350	450	1000	630	400
350	270	500	370	460	1100	650	440
400	310	500	370	460	1100	650	480
450	350	600	400	480	1150	700	590
500	350	650	410	480	1250	750	680
600	400	730	550	480	1250	1000	850
700	480	810	610	480	1250	1000	1350
800	600	870	650	480	1250	1000	1700
900	750	1000	750	550	1350	1200	2300
1000	900	1150	850	700	1350	1300	2800
1200	1100	1250	950	1200	1450	1500	3800

Dimensions and weights are preliminary only. Final dimensions and weights will be established after detail design of each valve is completed.